

IMPORTANT NOTICE

Parts of this manual are used by permission of MaxStream, Inc. All rights to this manual are owned solely by SATEL Oy (referred to in this user guide as SATEL). All rights reserved. The copying of this manual (without the written permission from the owner) by printing, copying, recording or by any other means, or the full or partial translation of the manual to any other language, including all programming languages, using any electrical, mechanical, magnetic, optical, manual or other methods or devices is forbidden.

SATEL reserves the right to change the technical specifications or functions of its products, or to discontinue the manufacture of any of its products or to discontinue the support of any of its products, without any written announcement and urges its customers to ensure, that the information at their disposal is valid.

SATEL software and programs are delivered "as is". The manufacturer does not grant any kind of warranty including guarantees on suitability and applicability to a certain application. Under no circumstances is the manufacturer or the developer of a program responsible for any possible damages caused by the use of a program. The names of the programs as well as all copyrights relating to the programs are the sole property of SATEL. Any transfer, licensing to a third party, leasing, renting, transportation, copying, editing, translating, modifying into another programming language or reverse engineering for any intent is forbidden without the written consent of SATEL.

SATEL PRODUCTS HAVE NOT BEEN DESIGNED, INTENDED NOR INSPECTED TO BE USED IN ANY LIFE SUPPORT RELATED DEVICE OR SYSTEM RELATED FUNCTION NOR AS A PART OF ANY OTHER CRITICAL SYSTEM AND ARE GRANTED NO FUNCTIONAL WARRANTY IF THEY ARE USED IN ANY OF THE APPLICATIONS MENTIONED.

Salo, FINLAND 2008

RESTRICTIONS ON USE

WARNING: This equipment has been is approved only for mobile and base station transmitting devices. Antenna(s) used for this transmitter must be installed to provide a separation distance of at least 30 cm from all persons and must not be co-located or operating in conjunction with any other antenna or transmitter.

Contains FCC ID: OUR-9XTEND. The enclosed device complies with the part 15 of the FCC rules. Operation is subject to the following two conditions: (i.) this device may not cause harmful interference and (ii.) this device must accept any interference received, including interference that may cause undesired operation.

PRODUCT CONFORMITY

Hereby, SATEL Oy declares that SATELLINE-1915 radio modem is in compliance with the essential requirements of FCC Part 15 (USA), IC (Industry Canada) and C-TICK (Australia) regulations.

WARRANTY AND SAFETY INSTRUCTIONS

Read these safety instructions carefully before using the product:

- Warranty will be void, if the product is used in any way, which is in contradiction with the instructions given in this manual, or if the housing of the radio modem has been opened or tampered with.
- The radio modem is to be used only on frequencies allocated by local authorities and without exceeding the given maximum allowed output power ratings. SATEL is not responsible, if any products manufactured by it are used in unlawful ways.
- The devices mentioned in this manual are to be used only according to the instructions described in this manual. Faultless and safe operation of the devices can be guaranteed only if the transport, storage, operation and handling of the devices is appropriate. This also applies to the maintenance of the products.
- To prevent damage to both the radio modem and any terminal devices must always be switched OFF before connecting or disconnecting the serial connection cable. It should be ascertained that different devices used have the same ground potential. Before connecting any power cables the output voltage of the power supply should be checked.

TABLE OF CONTENTS

IMPORTANT NOTICE.....	1
RESTRICTIONS ON USE.....	2
PRODUCT CONFORMITY.....	3
WARRANTY AND SAFETY INSTRUCTIONS.....	4
TABLE OF CONTENTS.....	5
INTRODUCTION.....	7
1 SATELLINE-1915 RADIO DATA MODEM.....	8
1.1 SATELLINE-1915 Technical specifications.....	8
2 CONNECTIONS.....	9
2.1 Power Supply.....	9
2.2 DIN 41651-16 pin connector functions.....	10
2.2.1 Pin configuration.....	10
3 LEDS.....	13
3.1 LED-indicators.....	13
4 SERIAL INTERFACE.....	14
4.1 RS-23214.....	
4.2 Serial interface data format.....	14
4.3 Serial interface handshake.....	16
4.3.1 Software handshaking (XON/XOFF).....	16
4.3.2 Hardware handshaking (RTS/CTS).....	16
4.4 Serial interface packetization.....	17
5 RF INTERFACE.....	18

5.1	Transmitter	18
5.2	Receiver	19
5.3	Error checking	20
5.4	Radio data rate and packet length.....	20
6	COMMAND MODE	21
6.1	Configuration.....	21
6.1.1	Changing the settings with AT commands.....	21
6.1.2	Back-up method for entering the Command Mode.....	23
6.1.3	Changing the settings with Binary Commands.....	23
6.1.4	Restoring default settings.....	24
7	RADIO MODES	25
7.1	Radio packet	26
7.2	Addressing	27
7.2.1	API mode.....	27
7.3	Multiple Transmit	28
7.4	Acknowledgements	28
7.5	Short range point-to-point example.....	29
7.6	Short range point-to-multipoint example.....	30
7.7	Short range sensor example.....	30
7.8	Repeater	31
7.9	Long range point-to-point example with repeater	32
7.10	Long range point-to-multipoint example with repeater	33
8	SLEEP MODES.....	34
9	DIAGNOSTICS AND TESTING.....	36
10	APPENDIX A.....	40

INTRODUCTION

SATEL Oy is a Finnish electronics and telecommunications company specialised in the design and manufacturing of wireless data communication products. SATEL designs, manufactures and sells radio modems intended for use in applications ranging from data transfer to alarm relaying systems. End users of SATEL products include industrial companies, public organisations and private persons.

SATEL is one of the leading radio modem suppliers worldwide. The SATEL radio modems are type approved in most countries globally.

Primary characteristics of SATELLINE – 1915 are listed below:

- SATELLINE-1915 radio has a raw data rate of 9.6 kbps or 115.2 kbps
- SATELLINE-1915 radio modems DTE-interface (Data Terminal Equipment, user device) is electrically compatible with the RS-232 serial interface. RD, TD, RTS, CTS, DTR, DSR lines are implemented.
- Settings can be changed with AT commands or binary commands.
- SATELLINE-1915 radio modem software can be updated using a PC and special programming software.

User guide version information

This version of the User Guide is applicable for SATELLINE-1915 having the firmware version 2040 or later.

1 SATELLINE-1915 RADIO DATA MODEM

1.1 SATELLINE-1915 Technical specifications

RADIO TRANSCEIVER

Frequency Range	902 ... 928 MHz
Communication Mode	Half Duplex Frequency Hopping
Hopping Patterns	10 different
Channels in Hopping Pattern	50
Radio Speed	9600 / 115200 bps

RADIO TRANSMITTER

Carrier Power	1, 10, 100, 500, 1000 mW / 50 ohm
---------------	-----------------------------------

RADIO RECEIVER

Sensitivity	-110 dBm @ 9600bps (BER < 10E-4) -100 dBm @ 115200bps (BER < 10E-4)
-------------	--

MODEM

Interface	RS-232
Interface Connector	DIN41651-16pin (male)
Data Speed of Serial Interface	10 – 230400 bps (also non-standard baud rates between 10 ... 230400)
Data format	Asynchronous RS-232

GENERAL

Operating Voltage	+ 8... + 30 Vdc
Power Consumption (average)	< 0.72 VA (60 mA @ 12 V) Receive < 1.1 VA (90 mA @ 12 V / 10 mW) Transmit < 5.0 VA (420 mA @12 V / 1 W) Transmit < 0.024 VA (2 mA@12 V) Sleep mode
Temperature Range	
- Operating	-25 °C ... +55 °C (tests acc. To ETSI standards) -40 °C ... +75 °C (absolutely min. / max.)
- Storage	-40 °C ... +85 °C
Antenna Connector	Reverse Polarity SMA, 50 ohm, male
Housing	Plastic / Aluminium enclosure
Size H x W x D	125 x 57 x 19 mm
Installation Plate	130 x 63 x 1 mm
Weight	115 g

NOTE! Values are subject to change without notice.

2 CONNECTIONS

2.1 Power Supply

The allowed operating voltage is +8 - +30 Vdc. The pin 1 of the DIN41651-16 connector is connected to the positive power supply line. Negative power supply line (ground) is connected to pin 2 of the DIN41651-16 connector. The DTR-line of the radio modem which is connected to pin 14 can be used as an ON / STANDBY –switch.

Connecting the DTR to ground will turn the radio modem OFF. Leaving the DTR unconnected will turn ON the radio modem (the radio modem has internal pull-up for DTR).

The basic connection between a radio modem and the serial port (RS-232) of a PC is described in the schematic below.

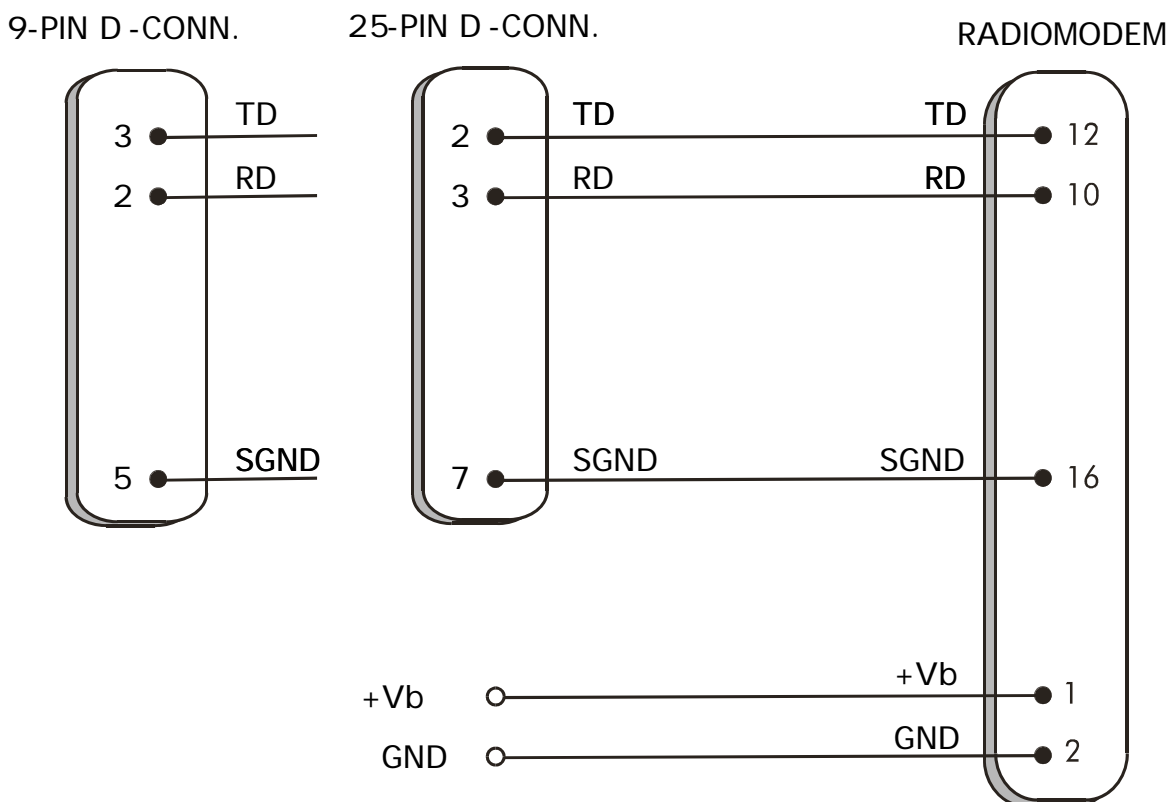

NOTE! The modem has an internal multifuse; external fuse is not required.

2.2 DIN 41651-16 pin connector functions

The radio modem is referred to as DCE (Data Communication Equipment) whereas the PC is referred to as DTE (Data Terminal Equipment). SATELLINE-1915 radio modem includes a 16-pin DIN41651-type male connector, which contains all the connections required to establish communication between the radio modem, acting as the DCE, and the PC, acting as the DTE.

All EMC-requirements set forth by authorities have been taken into account in the design of the radio modem. The user of the radio modem is thereby not required to take any special actions regarding EMC-shielding of the radio modem.

NOTE!

When the PROG-pin (pin 7 of the DIN41651-16 pin -connector) is connected to ground, the radio modem is in the *Programming Mode*.

2.2.1 Pin configuration

The pin configuration of the SATELLINE – 1915 is defined in the following table.
The picture below indicates the order of the pins.

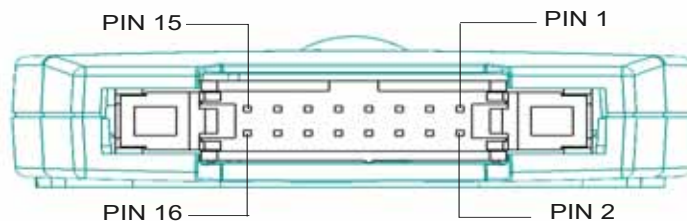

DIN41651-16 pin male connector of the radio modem
(the modem DTE-connector facing the viewer).

Direction **IN** is data from DTE (Data Terminal Equipment) to the radio modem.
Direction **OUT** is data from the radio modem to the DTE.

PORT	PIN	TO	NAME	EXPLANATION
PORT RS-232	9	OUT	DSR	Data set ready (internally connected to DTR)
	10	OUT	RD	Receive data
	11	IN	RTS/CMD	Ready to send / Binary Command Mode
	12	IN	TD	Transmit data
	13	OUT	CTS	Clear to send
	14	IN	DTR	Data terminal ready (modem ON / OFF, internal pull-up)
COMMON PINS	1	DC	Vb	DC supply voltage
	2	GND	GND	DC ground
	3	-	AUX IO1	do not connect
	4	-	AUX IO2	do not connect
	5	-	AUX IO3	do not connect
	6	IN	\SHDN	modem power down, active low (internal pull-up)
	7	IN	\PROG	AT Command Mode back-up method (internal pull-up)
	8	-	NC	not connected
	15	-	NC	not connected
	16	SGND	SGND	Signal ground

Description of pins:

RD = **Receive Data**. Output of the data received. Data from the radio modem to the DTE.

TD = **Transmit Data**. Input of the data to be transmitted. Data from the DTE to the radio modem.

CTS = **Clear To Send** in hardware handshake.

RTS/CMD = **Request To Send** or Binary Command Mode. The function of this line can be changed between hardware handshake (RTS), Binary Command Mode, or no handshake (default) EI TOIMI

DTR = **Data Terminal Ready**. Terminal in operation. When the DTR-line is left unconnected the radio modem is ON. If the DTR pins are connected to GND or SGND the radio modem will turn OFF.

DSR = **Data Set Ready**. Indicates that the radio modem is switched ON (internally connected to the DTR).

PROG = Back-up method for entering AT Command Mode. Ground this line at start-up to get to the Command Mode at 9600 bps regardless of the baud rate settings.

GND = negative pole of the operating voltage and the signal ground.

SGND = signal ground, internally connected to *GND*

+Vb = positive pole of the operating voltage.

NOTE!

GND and SGND are internally connected together.

3 LEDS

3.1 LED-indicators

There are five LED-indicators on the front panel of the radio modem and they give an indication of the status of the radio interface, serial port and power supply.

LED	Indication	OFF	Red	Green
TX	Radio transmission / Pin Sleep	No signal	Transmission / Constant red in Pin Sleep mode	
TD	TD-line status	No data	Data	
RX	Radio reception	No data		Reception
RD	RD-line status	Inactive		Data
PWR	Power	No power or DTR line is grounded		Radio modem ON

Description of the LED-indicators:

TX indicates that the radio modem is sending data via the antenna connector. If the Pin Sleep mode is enabled in the settings and the SHDN-line is grounded the radio modem will be in Pin Sleep mode and the TX is constant red.

TD indicates that the radio modem is receiving data via the serial port, TD-line, pin 12.

RX indicates that the radio modem is receiving data via the antenna connector.

RD indicates that the radio modem is sending data via the serial port, RD-line, pin 10.

PWR indicates the power is connected. If the DTR-line is grounded the radio modem is OFF.

4 SERIAL INTERFACE

4.1 RS-232

RS-232 standard defines the method of serial data transfer between a computer and its peripherals. The definition includes both the interface type and signal levels. Most computers and peripherals contain one or more RS-232 type serial ports. The RS-232 standard uses transmission lines, in which each single signal line level is referenced to a common ground level. RS-232 has been designed to be used in serial transfer of data in cases where the distance between communicating equipment is less than 15 m. The otherwise useful RS-232 standard is applied in a multitude of slightly differing ways (e.g. different pin configurations) and for this reason different computers and peripherals are not necessarily directly compatible with each other.

NOTE!

When connecting equipment using RS-232 make sure that the equipment are to be connected together or share the same ground potential (or that the signal ground of one and/or both of the devices are floating). Major differences in ground potentials will lead to large currents flowing in the SGND wire of the RS-232 interface which might lead to malfunctions or damage to the connected devices!

Supported standard serial speeds are 1200, 2400, 4800, 9600, 19200, 38400, 57600, 115200 and 230400 bps. Also non-standard baud rates are supported between 10 ... 230400 bps.

Hardware handshake can be used but it has to be set ON in command mode.

4.2 Serial interface data format

The SATELLINE-1915 radio modem serial interfaces use asynchronous data format. No external synchronising signal is needed, since necessary timing information is acquired from the start and stop bits transmitted before and after each data byte.

The data transfer speed of the serial interfaces can be set to 1200, 2400, 4800, 9600, 19200, 38400, 57600, 115200 and 230400 bps (**bits per second**). The length of the data field must be 8 bits. A parity bit may also be used. The number of stop bits can be selected (1 or 2 bits).

One character to be transmitted will thus contain a start bit, the data bits (which define the actual character in question), an optional parity bit and one or two stop bits. The overall length of one character is therefore 10, 11 or 12 bits. This should be taken into account when calculating the data throughput capability of a system. In other words, also the number of start, stop and parity bits must be considered. A useful rule of thumb is that at a data transfer speed of 9600 bps, the transmission of one character will require roughly one millisecond (1 ms).

Start	Data	Parity	Stop
-------	------	--------	------

Asynchronous character data format.

Example: With an 8-bit data character length and taking for example a decimal value of "204", which corresponds to a binary value of "11001100" and with a start bit value of "0", parity bit set to either "NO" (NONE), "0" or "1" and with a stop bit value of "1", the possible combinations are listed in the table below:

DATA FORMAT	CHARACTER	CHARACTER LENGTH
8 bit, no parity, 1 stop bit	0110011001	10 bit
8 bit, even parity, 1 stop bit	01100110001	11 bit
8 bit, odd parity, 1 stop bit	01100110011	11 bit
8 bit, mark parity, 1 stop bit	01100110011	11 bit
8 bit, space parity, 1 stop bit	01100110001	11 bit
8 bit, no parity, 2 stop bits	01100110011	11 bit
8 bit, even parity, 2 stop bits	011001100011	12 bit
8 bit, odd parity, 2 stop bits	011001100111	12 bit
8 bit, mark parity, 2 stop bits	011001100111	12 bit
8 bit, space parity, 2 stop bits	011001100011	12 bit

If the settings of data speed, character length, parity or the number of stop bits differ between the radio modem and the terminal, errors will be introduced into the transferred data. The serial port settings of each individual radio modem in a system can be different. In other words, the data transfer speed; parity and number of stop bits can be different in different parts of a same system.

AT / BIN	Description	Input	Default	Response
ATBD / 0x15	Query / Set serial data speed 0 = 1200 1 = 2400 2 = 4800 3 = 9600 4 = 19200 5 = 38400 6 = 57600 7 = 115200 8 = 230400	0-0x8	0x3	1 byte
ATNB / 0x23	Query / Set serial data parity 0 = no parity (or 7 bit with any parity) 1 = even 2 = odd 3 = mark 4 = space	0 - 0x4	0x0	1 byte
ATSB / 0x37	Query/Set serial data stop bits 0 = 1 stop bit 1 = 2 stop bits	0-0x1	0x0	1 byte

4.3 Serial interface handshake

When using the RS-232 serial interface, handshake signals can be used to control the data transfer. Handshaking is used by the terminal to request a permission to send data to the radio modem. Handshaking is used by the radio modem to inform the terminal that the radio modem serial data input buffer is has space or is full. By default handshaking is used to stop data flow when there is space for only 17 bytes in input buffer. The input buffer size is 2048 bytes. SATELLINE-1915 supports software and hardware handshaking.

4.3.1 Software handshaking (XON/XOFF)

In software handshaking (XON/XOFF) the radio modem will transmit XOFF character (0x13) to the terminal when the input buffer is full. When the input buffer has space the radio modem will transmit XON character (0x11) to the terminal to continue transmission.

4.3.2 Hardware handshaking (RTS/CTS)

In hardware handshaking (RTS/CTS) separate signal lines are used to control the data flow.

Line	Direction
RTS (Request To Send)	To radio modem
CTS (Clear To Send)	To terminal

The terminal asserts RTS line when it wants to transmit and radio modem will respond with asserting CTS, if there is space in the input buffer.

AT / BIN	Description	Input	Default	Response
ATFT / 0x24	Query/Set input buffer limit for handshaking	0-(input buffer size minus 17)	Input buffer size minus 17	1 byte
ATFL / 0x07	Query/Set software handshake (XON/XOFF) 0 = Disabled 1 = Enabled	0 – 0x1	0x0	1 byte
ATRT / 0x16	Query/Set RTS line behavior 0 = Disabled 1 = Enable Binary Commands 2 = Enable RTS (affects immediately)	0-0x2	0x0	1 byte
ATCS / 0x1F	Query/Set CTS line behavior 0 = Enable CTS 2 = CTS line always high 4 = CTS line always low	0-0x4	0x0	1 byte

4.4 Serial interface packetization

The radio modem will start the radio transmission when the following criteria is met:

1. After receiving more than 2048 bytes (default value for ATRB) from the serial line

OR

2. After receiving at least 1 byte AND seeing 3 characters (default value for ATRO) time of silence in the serial line. If the packetization time out has been set to 0, then ATRB bytes must be received in the serial line before beginning transmission

The value for the ATRB has to be equal or smaller than the value for the maximum radio packet (ATPK, default 0x800).

AT / BIN	Description	Input	Default	Response
ATRB / 0x20	Query/Set serial interface packetization byte threshold	0 – ATPK (max. 0x800)	0x800	2 byte
ATRO / 0x21	Query/Set serial interface packetization timeout in characters	0 - 0xFFFF	0x3	2 byte

5 RF INTERFACE

The antenna connector type is a RPSMA (male) with an impedance of 50 Ω .

The user can select the hopping pattern from 10 different predefined hopping patterns. Every hopping pattern uses 50 different frequencies within the 902 - 928 MHz frequency band.

The raw data rate of the radio interface is always fixed (9.6 or 115.2 kbps) irrespective of the data speed of the serial interface. In cases where the terminal speed exceeds the throughput of the radio interface, the modem will buffer the data in order to prevent data loss.

5.1 Transmitter

The output power of the transmitter is adjustable. The greatest allowable power, which must not be exceeded, depends on the limits set by local authorities. The output power of the transmitter should be set to the smallest possible level, which still ensures error free connections under variable conditions. Large output power levels using short connection distances can in the worst-case cause disturbances to the overall operation of the system.

OUTPUT POWER	dBm
1 mW	0
10 mW	+10
100 mW	+20
500 mW	+25
1000 mW	+30

Possible output power settings of the SATELLINE-1915 radio modem.

AT / BIN	Description	Input	Default	Response
ATPL / 0x3A	Query / Set transmitter power level 0 = 1 mW 1 = 10 mW 2 = 100 mW 3 = 500 mW 4 = 1000 mW	0-0x4	0x4	1 byte

NOTE!

Setting the radio data modem output power level to levels exceeding regulations set forth by local authorities is strictly forbidden. The setting and/or the use of non-approved power levels may lead to prosecution. SATEL is not responsible for any illegal use of its radio equipment, and is not responsible in any way for any claims or penalties arising from the operation of its radio equipment in ways contradictory to local regulations and/or requirements and/or laws.

The transmitter can be set to transmit only mode.

AT / BIN	Description	Input	Default	Response
ATTX / 0x3F	Query / Set transmission only mode 0 = TX & RX 1 = TX only	0-0x1	0	1 byte

5.2 Receiver

The receiver sensitivity is -110 dBm at radio speed 9,6 kbps and -100 dBm at radio speed 115,2 kbps.

The signal strength of the last received radio packet (RSSI), current signal strength of one channel and current signal strengths of all the hopping channels can be queried with AT commands.

AT / BIN	Description	Input	Default	Response
ATDB / 0x36	Query signal strength of the last received radio packet. If no packets have been received the value is 0x8000.	---	---	Depends on ATCF 0: -80 dBm<CR> 1: 50<CR> 2: -80<CR>
ATRC / ---	Query current signal strength of one channel (one of the 50 channels of the hopping pattern).	0-0x31	---	Depends on ATCF 0: -80 dBm<CR> 1: 50<CR> 2: -80<CR>
ATRM	Query current signal strength of all the 50 hopping channels. If parameter is given, the channels are scanned for that time in seconds and the result is the peak power value.	0-0x7D0 (2000 seconds)	---	Depends on ATCF

The response of ATRM depends on the ATCF value. The channels are numbered from 0 to 49.

ATCF=0	ATCF=1	ATCF=2
...
Ch 40: -80 dBm	50	-80 dBm
Ch 41: -86 dBm	56	-86 dBm
Ch 42: -103 dBm	67	-103 dBm
Ch 43: -92 dBm	5C	-92 dBm
...

5.3 Error checking

SATELLINE-1915 has a 16-bit CRC error checking for the radio packets. The received packets with erroneous CRC will be dropped.

5.4 Radio data rate and packet length

The radio data rate can be set to 9600 bps or 115200 bps (default).

AT / BIN	Description	Input	Default	Response
ATBR / 0x39	Query / Set radio data rate 0 = 9600 bps 1 = 115200 bps	0-0x1	0x1	1 byte

The maximum length of a radio packet can be limited. The maximum length of the radio packet is 256 bytes at radio data rate 9600 bps and 2048 bytes at radio data rate 115200 bps. If the radio data speed is lowered from 115200 to 9600 bps, the maximum radio packet length is set bigger than 0x100 (D256).

The maximum length of a radio packet also affects serial data packetization settings. The serial interface packetization value (ATRB) must be equal or smaller than ATPK. The ATRB value is automatically lowered to match ATPK.

AT / BIN	Description	Input	Default	Response
ATPK/ 0x29	Query / Set radio packet maximum size 0 = TX & RX 1 = TX only	0-0x800	0x100@9600 0x800@115200	2 bytes

6 COMMAND MODE

6.1 Configuration

The settings of SATELLINE-1915 are fully configurable with AT commands or binary commands.

6.1.1 Changing the settings with AT commands

- Connect cables (RS-232 cable to PC COM-port, power supply cable to power supply).
- Switch on the PC and start a terminal program.
- Open a terminal window and select serial port parameters as follows: 9600 bit/s, 8 data bits, no parity, 1 stop bit. These are the default settings. If serial parameters are changed the changed parameters should be used for entering command mode
- Type **+++** to the radio modem (do not use enter) within one second to enter the Command Mode. Note the Guard Time before (default 1 second), when no data should be sent.
- The radio modem will respond with **OK**
- Make desired changes to the settings. The AT commands have two types, a query and a setting. A query has a format **ATXX<enter>**, where **XX** is the command. A setting has a format **ATXXvalue<enter>**, where value is the desired setting. All the commands must end to carriage return (enter). The radio modem will respond to commands with **OK** or with a value.
- To save the changes permanently type **ATWR<enter>**.
- To exit the command mode type **ATCN <enter>**. The radio modem will exit automatically the command mode after an inactivity timeout (default 2 seconds), which can be changed.

User Input	Radio Modem Response	Description
+++	OK<CR>	Set the radio modem to command mode
ATPL<enter>	4<CR>	Query transmitter power level
ATPL3<enter>	OK<CR>	Set the power level to 3 (500 mW)
ATPL<enter>	3<CR>	Query transmitter power level
ATWR<enter>	OK<CR>	Save the changes
ATCN<enter>	OK<CR>	Exit the command mode

```

+++OK
atpl
4
atpl3
OK
atpl
3
atwr
OK
atcn
OK

```

An example of using the AT commands in terminal program.

The responses for the AT Commands have three types: value, OK or ERROR. In the command descriptions only value response type is mentioned, excluding the carriage return.

The Guard Times for Command Mode can be changed with AT commands.

AT / BIN	Description	Input	Default	Response
ATBT / 0x04	Query/Set Guard Time before + + + in 100 milliseconds	0-0xFFFF	0x0A	2 bytes
ATAT / 0x05	Query/Set Guard Time after + + + in 100 milliseconds	0-0xFFFF	0x0A	2 bytes
ATCC / 0x13	Query/Set character for Command Mode	0x20-0x7F	0x2B (ASCII '+')	1 byte
ATCT / 0x06	Query/Set Command Mode inactivity timeout in 100 milliseconds	0x02-0xFFFF	0xC8	1 byte

The value format of the AT commands can be changed between decimal or hexadecimal with units, hexadecimal without units and decimal or hexadecimal without units. The value is in decimal or hexadecimal depending on the command. The following commands have always their response in hexadecimal:

- ATVR (Firmware Version)
- ATHV (Hardware Version)
- ATKY (AES Encryption Key)

AT / BIN	Description	Input	Default	Response
ATCF / ---	Query/Set command format 0= decimal/hexadecimal with units 1 = forced to hexadecimal without units 2 = decimal/hexadecimal without units	0-0x2	0x1	1 byte

Query	Description	ATCF=0	ATCF=1	ATCF=2
AT%V<enter>	Query Voltage	5.36 V<CR>	55EBF<CR>	5.36<CR>
ATMY<enter>	Query Source Address	FFFF<CR>	FFFF<CR>	65535<CR>

Responses in different formats.

AT / BIN	Description	Input	Default	Response
ATCF / ---	Query/Set command format 0= decimal/hexadecimal with units 1 = forced to hexadecimal without units 2 = decimal/hexadecimal without units	0-0x2	0x1	1 byte

6.1.2 Back-up method for entering the Command Mode

If the baud rate settings of the serial port have been changed and they are not known, the back-up method for entering the Command Mode can be used.

Before powering up the radio modem, ground the PROG line (pin 7). When the radio modem is powered up, it will enter the Command Mode automatically with serial port speed 9600 bps. Now the AT-commands can be used to change settings, if necessary. Remember to disconnect the PROG-signal from the ground after the changes.

6.1.3 Changing the settings with Binary Commands

Binary Commands are like AT Commands and can be used to achieve faster performance for setting and querying the settings. There are differences in the usage.

1. Binary Commands must first be enabled with AT Commands. The AT Command ATRT controls the behavior of the RTS/CMD line. Therefore, when Binary Commands are used, hardware handshaking cannot be used.
2. Every time a Binary Command is to be issued, the RTS/CMD line must be asserted high and on the other times it must be driven low.
3. The Binary Commands are given in binary. No <enter> is needed. Parameters are sent least significant byte first. The ATCF command cannot be used.

AT / BIN	Description	Input	Default	Response
ATRT / 0x16	Query / Set RTS / CMD line behavior 0= Disabled 1 = Binary Commands ON 2 = RTS hardware handshake ON	0-0x2	0x0	1 byte

An example of using binary commands to change the source address:

ATRT has been set to 1.

RTS/CMD line is asserted high 10 ms before.

MY command, the parameter '0x1A0F' and WR commands are sent to the radio modem:

'0x24' MY Command,

'0x0F' least significant byte,

'0x1A' most significant byte,

'0x08' WR Command.

Responses can be omitted for faster performance.

RTS/CTS line is driven low 10 ms after.

6.1.4 Restoring default settings

It is possible to use the ATRE command to restore the default settings. If the serial port parameters have been changed, the new parameters must be used in communication.

To save the default settings permanently ATWR must be issued.

AT / BIN	Description	Input	Default	Response
ATRE / 0x0E	Set default settings	---	---	---

7 RADIO MODES

SATELLINE-1915 has different radio modes for different needs in communication. All the radio modems have always radio addresses. If there is a need to transmit data to a certain radio modem, the addresses can be set individually. Otherwise the addresses can be broadcast addresses.

To increase the reliability of the communication SATELLINE-1915 has two different means to achieve it; Acknowledgements and Multiple Transmits. When Acknowledgements are used, the transmitting radio modem waits for an Acknowledgement from the receiving radio modem and transmits again, if there is no Acknowledgement. There is a random delay for re-transmissions, if needed. Acknowledgements are not used when a packet is transmitted to a broadcast address (0xFFFF). With Multiple Transmit every packet is sent multiple times in a row.

To increase the range of the radio modems, repeaters can be used. With repeaters, Acknowledgements cannot be used. To avoid collisions in the air, a random delay is implemented in the repeaters. However, as the delay is random, it is not totally collision free.

To use the radio modems for example with sensor applications, polling mode can be used. In polling mode the polling radio modem (Polling Base) polls the other radio modems (Polling Remote) in order. In polling mode the repeaters cannot be used.

The best mode depends on the user application and network type. In short ranges point-to-point (p-to-p), point-to-multipoint (p-to-mp) and sensor applications are possible. In longer ranges with repeaters only point-to-point and point-to-multipoint are possible.

In point-to-point and point-to-multipoint network the application should be polling, in other words a master and a slave(s). If the application allows both or many user devices to transmit at the same time, random delay with acknowledgements can be used. This is not totally collision free, but the performance is adequate in most cases.

Network	Addresses	Reliability	Repeaters	Radio Polling
Short range p-to-p	Broadcast	Multiple Transmits	No	No
Short range p-to-p	Individual	Multiple Transmits or Acknowledgements	No	No
Short range p-to-mp	Broadcast	Multiple Transmits	No	No
Short range p-to-mp	Individual	Multiple Transmits or Acknowledgements	No	No
Short range sensor application	Individual	Multiple Transmits or Acknowledgements	No	Yes
Long range p-to-p	Broadcast	Multiple Transmits	Yes	No
Long range p-to-p	Individual	Multiple Transmits	Yes	No
Long range p-to-mp	Broadcast	Multiple Transmits	Yes	No
Long range p-to-mp	Individual	Multiple Transmits	Yes	No

AT / BIN	Description	Input	Default	Response
ATMD / 0x31	Query / Set Radio Mode 0 = Normal operation 3 = Polling Base 4 = Polling Remote 5 = Repeater 6 = Repeater End	0-6	0	1

7.1 Radio packet

SATELLINE-1915 has following settings that need to be correct before data can be received.

1. The hopping pattern must be same in the radio modems.
2. The Vendor ID must be the same in the radio modems.
3. The Destination Address in the transmitting radio modem must match the settings in the receiving radio modem.

The SATELLINE-1915 has following radio packet structure:

INITIALIZER - HOPPING PATTERN - VENDOR ID - DT - PID - DATA - CRC-16

The Initializer is sent every time a new connection sequence begins to synchronize the radio modems. The length of the Initializer is different when the sleep mode is used. By default the Initializer is 6 milliseconds at 115200 bps radio data rate.

The hopping pattern information is used to verify that the data packet received had the same hopping pattern setting.

Vendor ID is used to verify that the receiving radio modem has the same Vendor Id setting as the transmitter.

The Destination Address is used to check if the data packet should be received or not.

The Packet Identifier is used with repeating and Acknowledgements. The Packet Identifier includes the source address (ATMY) of the transmitting radio modem and a running number for the packet. If the radio modem has already received a packet with the same Packet Identifier, the current packet is not sent to the serial line or repeated. The Packet Identifier is used with Acknowledgements to separate which packet has been acknowledged.

The User Data field has the data the user wants to transmit.

The CRC-16 is used to check the correctness of the packet. Received packets with erroneous CRC-16 are discarded.

AT / BIN	Description	Input	Default	Response
ATHP / 0x11	Query/Set Hopping Pattern	0-9	0	1
ATID / 0x27	Query/Set Vendor ID	0-0x7FFF	0x3332	2

7.2 Addressing

SATELLINE-1915 has three settings for addresses, Destination Address (ATDT), Source Address (ATMY) and Address Mask (ATMK).

When the radio modem receives a radio packet, the Destination Address is first matched with Address Mask. The matching is a bitwise binary ANDing. If the result is the same as the Address Mask, the received packet is sent to the serial port. Next the receiving packet is matched to the receiving radio modems Source Address (ATMY). If the result of the matching is Source Address of the receiving radio modem, the received packet is for this receiver and sent to the serial port. If the Destination Address of the received packet does not match Mask or Source address, it is discarded. The Mask and the Source address are off, when they are in the default value 0xFFFF.

Examples:

DT = Destination Address in the packet. This is the setting in the transmitting radio modem.

MK = Address Mask setting in the receiving radio modem.

MY = Source Address setting in the receiving radio modem.

Transmitter DT	Receiver MK	Receiver MY	Reception
0x0000	0xFFFF	0xFFFF	YES (global DT address)
0x0000	0xFFFF	0xABCD	NO (no match)
0xFFFF	0xFFFF	0xFFFF	YES (match with MK)
0xFFFF	0xFFFF	0xABCD	YES (match with MK)
0xABCD	0xFFFF	0xFFFF	NO (no match)
0xABCD	0xABCD	0xFFFF	YES (ANDing with MK)
0xABCC	0xABCD	0xFFFF	NO (no match)
0xABCD	0xFFFF	0xABCD	YES (match with MY)
0x000C	0x0004	0xABCD	YES (ANDing with MK)
0x000C	0xABCD	0x0004	NO (no ANDing or match)
---	0x0000	---	YES (sniffer mode)

Using the Address Mask it is possible to build network with different sub networks, if needed.

In the sniffer mode, when the Address Mask is set to 0, all data is received but no Acknowledgements are sent even if they are set. If the Acknowledgements are in use in the transmitting radio modem, the data will be seen as many times as is the Retry (ATRR) value, when the transmitting radio modem transmits the data again.

AT / BIN	Description	Input	Default	Response
ATDT / 0x00	Query/Set Destination Address	0-0xFFFF	0	2
ATMK / 0x12	Query/Set Address Mask	0-0xFFFF	0xFFFF	2
ATMY / 0x2A	Query/Set Source Address	0-0xFFFF	0xFFFF	2

7.2.1 API mode

It is possible to transmit and receive packets to the radio modem in serial line using API (Application Packet Interface) packet format. In this format, it is possible to set the destination

address of the packet. The packets from the radio modem serial line include the information of the success of the packet transmission and signal strength of the received packets. Ask more details for the implementation from SATEL Oy or its local distributors worldwide.

7.3 Multiple Transmit

To increase the reliability SATELLINE-1915 radio modem has a multiple transmit mode. In this mode, every packet from the serial line is sent multiple times in the radio without breaks. Each retransmission has the radio initializer to maximize the reception. The receiving radio modem will send the received radio data to the serial line only once. This feature can be used with short packets, where Acknowledgements would take longer time. By default the Multiple transmit is OFF. The Multiple Transmit will be used, if the Acknowledgements and the Multiple transmit are both ON at the same time. The radio packets are sent ATMT + 1 times, so with default ATMT value 0, radio packets are sent once.

AT / BIN	Description	Input	Default	Response
ATMT / 0x3D	Query/Set Multiple Transmit value.	0-0xFF	0xA	1 byte

7.4 Acknowledgements

To increase the reliability SATELLINE-1915 radio modem has Acknowledgements. If enabled, the transmitting radio modem will wait for an Acknowledgement for the transmitted radio packet from the receiving radio modem. If no Acknowledgement is received the packet is sent again, until an Acknowledgement is received or the packet has been sent the maximum amount of Acknowledgement Retry times. By default, the value is 10 (0xA). If the ATMT value is different from 0, the Multiple Transmit has precedence over the Acknowledgements and Acknowledgements are not used. The Acknowledgements cannot be used with repeaters.

To avoid a situation that two or more user devices and radio modems transmit at the same time resulting in a collision in the air, Random Delay Slots can be defined. Without Random Delay Slots following could happen: Two or more user devices transmit at the same time. The radio packets collide in the air and no Acknowledgements are received. Therefore, every radio modem transmits the radio packet again. Again, collision happens. This repeats until all the radio modems have sent the packets ATRR times. If the ATRR is 0, no Acknowledgements are used. When ATRR is 1, the packet is transmitted at maximum 2 times, if no Acknowledgement has been received.

If the Random Delay Slots are enabled, a random time is waited after a transmission without an Acknowledgement and before the next attempt.

If the Destination Address of the transmitting radio modem is a broadcast address (0xFFFF), Acknowledgements must be set to 0. Otherwise, every radio packet is transmitted ATRR-1 times, because no receiving radio modem will acknowledge.

AT / BIN	Description	Input	Default	Response
ATRR / 0x18	Query / Set Acknowledgement Retry value Disabled if ATRR = 0, ATMT > 0 or ATDT = 0xFFFF	0-0xFF	0xA	1 byte
ATRN / 0x19	Query / Set Random Delay Slot amount. This value is also used with repeaters.	0-0xFF	0	1 byte
ATTR / 0x1B	Query / Set the amount of missed Acknowledgements. Non-volatile.	0-0xFFFF	0	2 byte

7.5 Short range point-to-point example

Here is an example for point-to-point network with two radio modems. This is the easiest way with default addresses.

Radio modem 1	Radio modem 2
MD = 0x0 (default)	MD = 0x0 (default)
MY = 0xFFFF (default)	MY = 0xFFFF (default)
MK = 0xFFFF (default)	MK = 0xFFFF (default)
DT = 0x0 (default)	DT = 0x0 (default)
RR = 0x0	RR = 0x0
MT = 0x0 (default)	MT = 0x0 (default)

ATRR should be set to 0 from the default value 0xA (10), otherwise both radio modems will transmit every radio packet 10 times, because no Acknowledgements are received for broadcast address ATDT=0. Effectively, this has the same effect as using the Multiple Transmission with value 9. Naturally, this affects the throughput. In any case, only one received packet is sent to the serial port.

To use the Acknowledgements with individual addresses, the following setup is recommended.

Radio modem 1	Radio modem 2
MD = 0x0 (default)	MD = 0x0 (default)
MY = 0x1	MY = 0x2 (default)
MK = 0xFFFF (default)	MK = 0xFFFF (default)
DT = 0x0	DT = 0x1
RR = 0xA	RR = 0xA
MT = 0x0 (default)	MT = 0x0 (default)

In this setup, the radio packets are only sent once, if the Acknowledgement is received.

7.6 Short range point-to-multipoint example

In short range point-to-multipoint setup addresses can be used as a broadcast or from an application master to the application slaves and back. In this setup the destination addresses are broadcast addresses, and every device will receive every packet.

Radio modem 1	Radio modem 2	Radio modem 3
MD = 0x0 (default)	MD = 0x0 (default)	MD = 0x0 (default)
MY = 0xFFFF (default)	MY = 0xFFFF (default)	MY = 0xFFFF (default)
MK = 0xFFFF (default)	MK = 0xFFFF (default)	MK = 0xFFFF (default)
DT = 0x0 (default)	DT = 0x0 (default)	DT = 0x0 (default)
RR = 0x0	RR = 0x0	RR = 0x0
MT = 0x0 (default)	MT = 0x0 (default)	MT = 0x0 (default)

If the application is polling, individual addresses are recommended. In this setup all the application slaves will receive the data from the application master. The application slaves will not receive data from other application slaves. The application master will receive the data from all application slaves.

Radio modem 1 (master)	Radio modem 2 (slave)	Radio modem 3 (slave)
MD = 0x0 (default)	MD = 0x0 (default)	MD = 0x0 (default)
MY = 0x1	MY = 0x2	MY = 0x3
MK = 0xFFFF (default)	MK = 0xFFFF (default)	MK = 0xFFFF (default)
DT = 0xFFFF	DT = 0x1	DT = 0x1
RR = 0x0	RR = 0x0	RR = 0x0
MT = 0x0 (default)	MT = 0x0 (default)	MT = 0x0 (default)

7.7 Short range sensor example

If the application has devices that can transmit data at any time the collisions in the air will affect the behaviour. For example multiple sensors that need to transmit information to the base. Therefore, it is recommended to use SATELLINE-1915 Radio Polling. In Radio Polling, one radio modem is set as a Polling Base and the others are Polling Remotes. The Polling Base can transmit at any time, but the Polling Remotes can only transmit when the Polling Base polls them. The radio modems must have individual addresses and the polled addresses must be defined in the Polling Base. The time between polling can also be defined.

Radio modems

Polling Base	Polling Remote 1	Polling Remote 2
MD = 0x3	MD = 0x4	MD = 0x4
MY = 0x0	MY = 0x2	MY = 0x3
MK = 0xFFFF (default)	MK = 0xFFFF (default)	MK = 0xFFFF (default)
DT = 0xFFFF	DT = 0x0	DT = 0x0
RR = 0x0	RR = 0x0	RR = 0x0
MT = 0x0 (default)	MT = 0x0 (default)	MT = 0x0 (default)
PB = 0x2	PB = 0x0 (default)	PB = 0x0 (default)
PE = 0x3	PE = 0x3 (default)	PE = 0x3 (default)
PD = 64 (default)	PD = 64 (default)	PD = 64 (default)

The addresses must be set up correctly. For reliability the Acknowledgements (ATRR) or Multiple Transmits can be used (MTRR). The ATPD value is at the Base the minimum time between polls, in this example 64 milliseconds. The ATPD value at the Remote is the time how long the Remote unit buffers the serial line data, in this case 640 milliseconds. The value is the same but at the Remote it is 10x bigger. It is advisable to use the same ATPD value at the Polling Remote, so no data is lost, if there is more transmissions from other Polling Remotes. If the ATPD value is 0x3E8 (1000), the Polling Base will first poll the first Polling Remote and then the other in this example. After the polling there is a one second break.

Note! The Radio Polling is not shown in the TX led of the radio modem, only in the RX led.

7.8 Repeater

SATELLINE-1915 radio modem has a store-and-forward repeater function for extending the coverage of the radio modems. In a radio network configuration with repeater, at least one unit must be a repeater and multiple units can be repeater end nodes. If the radio packet is addressed to the repeating radio modem, it will not repeat it. Based on the packet information field in the radio packet, the receiving device will send the received radio packet only once to the serial port. Multiple instances of the same radio packet are discarded in the receiving device.

When the network has a repeater, the Radio Mode of all the devices has to be set to a repeater or to a repeater end node, if the radio modem is not repeating. When a repeater or repeater end node mode has been selected the Acknowledgements are disabled and have to be manually enabled, if the repeater mode is not more used.

With repeater network, only one message at the time should be in the radio network. The repeater has a possibility for a random delay before repeating. The random delay depends on the ATRN value and the received signal strength (RSSI). With ATRN value it is possible to have basic level for the delay and the RSSI makes the delay different for repeaters with same ATRN. With four repeaters in the same range receiving the same message, with different ATRN and RSSI values the following would happen. In this example it is assumed, that the packet is not intended for any of the repeaters.

B (Base) – R1-R2---R3-R4 (Repeaters 1, 2, 3, 4)

The radio packet is first transmitted and every repeater receives it. The R1 receives it with very good -40 dBm RSSI, the R2 with very bad -100 dBm RSSI, the R3 with very good -40 dBm RSSI and the R4 with very bad -100 dBm. The delays for repeating are:

R1, ATRN=1, RSSI= -40	R2, ATRN=1, RSSI= -100	R3, ATRN=2, RSSI= -40	R2, ATRN=2, RSSI= -100
Delay 1	Delay 59	Delay 2	Delay 118

The R1 repeats the radio packet first. Next time, assuming the same signal strengths, the values are:

R1, ATRN=1, RSSI= -40	R2, ATRN=1, RSSI= -100	R3, ATRN=2, RSSI= -40	R2, ATRN=2, RSSI= -100
	Delay 59	Delay 2	Delay 118

The R3 will repeat the radio packet. Assuming again, the same signal strengths, the delays are:

R1, ATRN=1, RSSI= -40	R2, ATRN=1, RSSI= -100	R3, ATRN=2, RSSI= -40	R2, ATRN=2, RSSI= -100
	Delay 59		Delay 118

This time, the R2 will repeat the radio packet.

The delays in the example are in values for comparison only, not in milliseconds. There is also a random variable added for the delay, if two repeaters have the same ATRN and RSSI value. The real length of the delay depends on the radio packet length, too.

The ATRN value is also used in the Repeaters or in the Repeater End Nodes to prevent the response too fast, resulting in a collision. With the same values the response delays would be:

R1, ATRN=1, RSSI= -40	R2, ATRN=1, RSSI= -100	R3, ATRN=2, RSSI= -40	R2, ATRN=2, RSSI= -100
Repeater Delay 1	Repeater Delay 59	Repeater Delay 2	Repeater Delay 118
Response Delay 3	Response Delay 79	Response Delay 5	Response Delay 148

So the ATRN value prevents the collisions from responses from any of the Repeaters or the Repeater End nodes.

7.9 Long range point-to-point example with repeater

The simplest configuration for a network with a repeater is one with addresses, where every device will receive every transmission. This may be an issue with some systems, where the application slaves will hear transmissions from other application slaves. The repeater does not take care of the collisions so the application should be polling.

End node (master)	Repeater	End node (slave)
MD = 0x6 (repeater end)	MD = 0x5 (repeater)	MD = 0x6 (repeater end)
MY = 0x1	MY = 0x2	MY = 0x3
MK = 0xFFFF	MK = 0xFFFF	MK = 0xFFFF
DT = 0xFFFF	DT = 0xFFFF	DT = 0xFFFF
RR = 0x0	RR = 0x0	RR = 0x0
RN = 0x0	RN = 0x0	RN = 0x0
Transmission and not to serial	Repeated and to serial	To serial only once
To serial only once	Transmission	To serial only once
To serial only once	Repeated and to serial	Transmission and not to serial

Multiple Transmits can be used for reliability but not the Acknowledgements. In this simple application, Random values (ATRN) need not to be set.

With two repeaters, the following settings are recommended.

End node (master)	Repeater 1	Repeater 2	End node (slave)
MD = 0x6 (repeater end)	MD = 0x5 (repeater)	MD = 0x5 (repeater)	MD = 0x6 (repeater end)
MY = 0x1	MY = 0x2	MY = 0x3	MY = 0x4
MK = 0xFFFF	MK = 0xFFFF	MK = 0xFFFF	MK = 0xFFFF
DT = 0xFFFF	DT = 0xFFFF	DT = 0xFFFF	DT = 0xFFFF
RR = 0x0	RR = 0x0	RR = 0x0	RR = 0x0
RN = 0x1	RN = 0x1	RN = 0x1	RN = 0x1

In this setup all the radio modems have random repeat and response delays on.

7.10 Long range point-to-multipoint example with repeater

For master-slave polling applications it is best to use system with broadcast destination address in the radio module connected to the application master and destination addresses to application master in radio modems connected to application slaves. Otherwise the configuration is the same as in the previous example.

End node (application master)	Repeater (application slave)	End node (application slave)
MD = 0x6 (repeater end)	MD = 0x5 (repeater)	MD = 0x6 (repeater end)
MY = 0x1	MY = 0x2	MY = 0x3
MK = 0xFFFF	MK = 0xFFFF	MK = 0xFFFF
DT = 0xFFFF	DT = 0x1	DT = 0x1
RR = 0x0	RR = 0x0	RR = 0x0
RN = 0x1	RN = 0x1	RN = 0x1

If the application has more than five radio modems, ATRN value 2 is recommended.

8 SLEEP MODES

The SATELLINE-1915 has three different sleep modes to be used for saving power. The sleep modes are Pin Sleep, Serial Port Sleep and Radio Cyclic Sleep.

For the maximum power saving the radio modem can be completely shut down grounding the pin 14, signal DTR.

In Pin Sleep the radio modem receiver is shut down for minimum amount of power. The shutting down is made grounding the pin 6 signal \ SHDN. The sleep mode must first be activated with ATSM setting (ATSM = 1). In Pin Sleep mode the PWR led is constant green and the TX led is constant red.

In Serial Port Sleep (ATSM = 2) the radio modem is in the sleep mode after a user-defined period of inactivity (ATST) in the serial line. The radio modem wakes up when there is data in the serial line. The radio receiver is shut down, so radio transmission will not wake the radio modem. This mode is not shown in the leds.

In Radio Cyclic Sleep the radio modem receiver is shut down and wakes up periodically to receive radio data if there is any. In this mode the Initializer of the radio packet must be set to be longer in the transmitting radio modem than the shut down period time in the receiving radio modem. Therefore, it is not possible to use this sleep mode with repeaters. It is possible to use the pin 6 signal \ SHDN to wake up the radio modem from the Radio Cyclic Sleep. When the radio modem is in the Cyclic Radio Sleep, the mode the PWR led is constant green and the TX led is constant red.

AT / BIN	Description	Input	Default	Response
ATSM / 0x01	Query / Set Sleep Mode 0 = Disabled 1 = Pin Sleep 2 = Serial Port Sleep 4 = Radio Cyclic 1 second period 5 = Radio Cyclic 2 second period 6 = Radio Cyclic 4 second period 7 = Radio Cyclic 8 second period 8 = Radio Cyclic 16 second period	0-8	0x0	1 byte
ATST / 0x02	Query/Set Time before sleep for Serial Port Sleep and Radio Cyclic Sleep in 100 ms	(ATAT + 3) - 0x7FF	0x64 (D100 = > 10 s)	2 byte
ATLH / 0x0C	Query/Set the length of Wake-Up Initializer in 100 ms. This must be longer than Cyclic period	0-0xFFFF	0	2 byte
ATHT / 0x03	Query/Set Time before Wake-Up Initializer in 100 ms. This must be shorter than ATST.	0-0xFFFF	0xFFFF (off)	2 byte
ATPW / 0x1D	Query/Set Pin Wake-Up in Radio Cyclic Sleep 0 = Disable 1 = Enable	0-1	0	1

An example of Radio Cyclic Sleep.

In this example the Cyclic Sleep Period is 4 seconds. The receiving radio modem is wake for 1 second after every 4 seconds. The transmitting radio modem that wakes the other radio modem has the length of the Wake-Up Initializer as same as the Cyclic Period and two times the wake-up time, so $4 + 1 + 1 = 6$ seconds. The transmitting radio modem has the time before the Wake-Up Initializer is sent 10% percent shorter than the ATST in the receiving radio modem.

Transmitting radio modem	Receiving radio modem
MD = 0x0 (normal)	MD = 0x0 (normal)
MY = 0xFFFF (default)	MY = 0xFFFF (default)
MK = 0xFFFF (default)	MK = 0xFFFF (default)
DT = 0x0 (default)	DT = 0x0 (default)
RR = 0x0	RR = 0x0
SM = 0 (default)	SM = 6
ST = 0x64 (default)	ST = 0xA (D10, 1000ms)
LH = 0x3C (D60, 6000 ms)	LH = 0 (default)
HT = 0x9 (900 ms)	HT = 0xFFFF (default, off)
PW = 0x0 (default)	PW = 0x0 (default)

The power usage is in the idle mode 1 W, in the Sleep mode 0.4 W and in the transmission with 1 W radio output power 6 W.

9 DIAGNOSTICS AND TESTING

DB (Received Signal Strength) Command

DB Command is used to read the receive signal strength (in decibels relative to mW) of the last received packet. This parameter is useful in determining range characteristics of the RF modules under various conditions. In default mode, this command shows the power level in signed decimal format with the units (dBm). If CF = 1, the magnitude of the value is presented in unsigned hex. If CF = 2, the value is presented in decimal, but without the units.

Sample output: -88 dBm (when ATCF = 0)
 58 (when ATCF = 1)
 -88 (when ATCF = 2)

NOTE: If the DB register is read before the module has received an RF packet, the module will return a value of 0x8000 (which means an RF packet has not yet been received).

ER (Receive Error Count) Command

The ER command is used to set / read the number of receive-errors. The error count records the number of packets partially received then aborted on a reception error. This value returns to 0 after a reset and is not non-volatile (value does not persist in the module's memory after a power-up sequence). Once the Receive Error Count reaches its maximum value (up to 0xFFFF), it remains at its maximum count value until the maximum count value is explicitly changed or the module is reset. The ER parameter is not reset by pin, serial port or cyclic sleep modes.

GD (Receive Good Count) Command

The GD command is used to set / read the count of good received RF packets. Its parameter value is reset to 0 after every reset and is not non-volatile (the parameter value does not persist in the RF module's memory after a power-up sequence). Once the "Receive Good Count" reaches its maximum value (up to 0xFFFF), it remains at its maximum count value until the maximum count value is manually changed or the module is reset.

The GD parameter is not reset by pin, serial port or cyclic sleep modes.

RC (Ambient Power - Single Channel) Command

The RC command is used to examine and report the power level on a given channel.

Sample output: -78 dBm [when CF = 0]
 4e [when CF = 1]
 -78 [when CF = 2]

RE (Restore Defaults) Command

The RE command is used to restore all configurable parameters to their factory default settings. The RE Command does not cause default values to be stored to non-volatile (persistent) memory. For the restored default settings to persist in the module's non-volatile memory and be saved in the event of RF module reset or power-down, the WR (Write) command must be issued prior to power-down or reset.

RM (Ambient Power - All Channels) Command

The RM command is used to examine and report power levels on all channels. If no parameter is given, the channels are scanned one time. If a parameter is given, the channels are repeatedly scanned for that number of seconds. The maximum power level seen for each channel is reported (i.e. peak hold). A graphical spectrum analyzer can be implemented by repeatedly sending the RM command (with no arguments) and reading the resultant 50 power levels (this is easiest to do when CF = 1 or 2).

```
Sample output [when CF = 0]:   Ch 0: -100 dBm
                               Ch 1: -103 dBm
                               ...
                               Ch 49: -99 dBm
Sample output [when CF = 1]:   64
                               67
                               ...
                               63
Sample output [when CF = 2]:   100
                               -103
                               ...
                               -99
```

SH (Serial Number High) Command

SH Command is used to set /read the serial number high word of the RF module.

SL (Serial Number Low) Command

SL Command is used to set /read the serial number low word of the RF module.

TP (Board Temperature) Command

TP Command is used to read the current temperature of the board.

TR (Transmit Error Count) Command

The TR command is used to report the number of retransmit failures. This number is incremented each time a packet is not acknowledged within the number of retransmits specified by the RR (Retries) parameter. The number of packets therefore is counted that were not successfully received and subsequently discarded. The TR parameter is not non-volatile and is reset to zero when the RF module is reset.

VL (Firmware Version - Verbose)

The VL command is used to read the verbose firmware version of the RF module.

WA (Active Warning Numbers) Command

The WA command reports the warning numbers of all active warnings - one warning number per line. No further information is shown and warning counts are not reset.

WN (Warning Data) Command

WN command is used to report the following data for all active and sticky warnings:

- Warning number & description
- Number of occurrences since the last WN or WS command
- Whether the warning is currently active

Warnings, which are not currently active and have not been active since the last issuance of the WN or WS commands, are not displayed. The WN command also resets all non-zero warning counts; except for warnings that are presently active, which are set to 1.

Warning #	Description
1	Under-voltage. This is caused if the internal supply voltage of modem falls below the minimum threshold for the lowest power level (2.8 V). If / when the voltage rises above the threshold, the warning is deactivated. The module will not transmit below this voltage threshold.
2	Over-voltage. This is caused if the internal supply voltage of modem exceeds 5.75 V. Transmission is not allowed while this warning is active.
3	Under-temperature. This is caused if the temperature sensed by the modem is less than -40 C. The modem does not artificially limit operation while this warning is active, but modem functionality is not guaranteed.
4	Over-temperature. This is caused if the temperature sensed by the modem is greater than 105 °C. The modem does not allow transmission nor reception while this warning is active. The warning is deactivated when the temperature falls to 100 °C.
5	Power reduced. This is caused if the transmit power has to be reduced from the level programmed by PL Command due to insufficient supply voltage. The 1 W power level requires internal supply voltage 4.75 V or higher; 500 mW requires 3.0 V or higher; 100 mW, 10 mW and 1 mW require 2.8 V or higher.
6	Default calibration data in flash. This is caused if the modem-specific power calibration data is either not present or is invalid, or if none of the parameters have been modified from their default values. Power levels may be incorrect.
7	Default configuration parameters in flash. This is caused if user-modifiable parameters (i.e. those stored by a 'WR' command) in flash are all the compiled-in default values. This is caused if the user configuration is found to be not present or invalid at power-up and there is no custom configuration, or if no user-modifiable parameters have been modified from the compiled-in defaults. Modification of one or more parameters without the subsequent WR to commit the changes to flash will not deactivate this warning, since it reflects the status of the parameters in flash. Note that this warning does not reflect usage of the custom configuration defaults, only usage of the compiled-in defaults.
8	Default factory configuration parameters in flash. This is caused if the factory parameters in flash are all the default values. This is caused if the factory configuration is found to be not present or invalid at power-up, or if no factory parameters have been modified.

WS (Sticky Warning Numbers) Command

The WS command reports warning numbers of all warnings active since the last use of the WS or WN command (including any warnings which are currently active). This command also resets all non-zero warning counts, except for warnings that are presently active, which are set to 1.

AT / BIN	Description	Input	Default	Response
ATDB / 0x36	Received Signal Strength	---	---	2 byte
ATER / 0x0F	Receive Error Count	---	0	2 byte
ATGD / 0x10	Receive Good Count	---	0	2 byte
ATRC	Ambient Power – Single Channel	---	---	1 byte
ATRE / 0x0E	Restore Defaults	---	---	---
ATRM	Ambient Power – All Channels	---	---	2 byte
ATSH / 0x25	Serial Number High	---	varies	2 byte
ATSL / 0x26	Serial Number Low	---	varies	2 byte
ATTP / 0x38	Board Temperature	---	---	1 byte
ATTR / 0x1B	Transmit Error Count	---	0	2 byte
ATVL	Firmware Version - Verbose	---	0	2 byte
ATWA	Active Warning Numbers	---	---	string
ATWN	Warning Data	---	---	string
ATWS	Sticky Warning Numbers	---	---	1 byte

10APPENDIX A

ASCII CHARACTER TABLE																	
D	H	A	D	H	A	D	H	A	D	H	A	D	H	A	D	H	A
0	0		43	2B	+	86	56	V	129	81		172	AC		215	D7	
1	1		44	2C	,	87	57	W	130	82		173	AD		216	D8	
2	2		45	2D	-	88	58	X	131	83		174	AE		217	D9	
3	3		46	2E	.	89	59	Y	132	84		175	AF		218	DA	
4	4		47	2F	/	90	5A	Z	133	85		176	B0		219	DB	
5	5		48	30	0	91	5B	[134	86		177	B1		220	DC	
6	6		49	31	1	92	5C	\	135	87		178	B2		221	DD	
7	7		50	32	2	93	5D]	136	88		179	B3		222	DE	
8	8		51	33	3	94	5E	^	137	89		180	B4		223	DF	
9	9		52	34	4	95	5F	_	138	8A		181	B5		224	E0	
10	A		53	35	5	96	60	`	139	8B		182	B6		225	E1	
11	B		54	36	6	97	61	a	140	8C		183	B7		226	E2	
12	C		55	37	7	98	62	b	141	8D		184	B8		227	E3	
13	D		56	38	8	99	63	c	142	8E		185	B9		228	E4	
14	E		57	39	9	100	64	d	143	8F		186	BA		229	E5	
15	F		58	3A	:	101	65	e	144	90		187	BB		230	E6	
16	10		59	3B	;	102	66	f	145	91		188	BC		231	E7	
17	11		60	3C	<	103	67	g	146	92		189	BD		232	E8	
18	12		61	3D	=	104	68	h	147	93		190	BE		233	E9	
19	13		62	3E	>	105	69	i	148	94		191	BF		234	EA	
20	14		63	3F	?	106	6A	j	149	95		192	C0		235	EB	
21	15		64	40	@	107	6B	k	150	96		193	C1		236	EC	
22	16		65	41	A	108	6C	l	151	97		194	C2		237	ED	
23	17		66	42	B	109	6D	m	152	98		195	C3		238	EE	
24	18		67	43	C	110	6E	n	153	99		196	C4		239	EF	
25	19		68	44	D	111	6F	o	154	9A		197	C5		240	F0	
26	1A		69	45	E	112	70	p	155	9B		198	C6		241	F1	
27	1B		70	46	F	113	71	q	156	9C		199	C7		242	F2	
28	1C		71	47	G	114	72	r	157	9D		200	C8		243	F3	
29	1D		72	48	H	115	73	s	158	9E		201	C9		244	F4	
30	1E		73	49	I	116	74	t	159	9F		202	CA		245	F5	
31	1F		74	4A	J	117	75	u	160	A0		203	CB		246	F6	
32	20		75	4B	K	118	76	v	161	A1		204	CC		247	F7	
33	21	!	76	4C	L	119	77	w	162	A2		205	CD		248	F8	
34	22	"	77	4D	M	120	78	x	163	A3		206	CE		249	F9	
35	23	#	78	4E	N	121	79	y	164	A4		207	CF		250	FA	
36	24	\$	79	4F	O	122	7A	z	165	A5		208	D0		251	FB	
37	25	%	80	50	P	123	7B	{	166	A6		209	D1		252	FC	
38	26	&	81	51	Q	124	7C		167	A7		210	D2		253	FD	
39	27	'	82	52	R	125	7D	}	168	A8		211	D3		254	FE	
40	28	(83	53	S	126	7E	~	169	A9		212	D4		255	FF	
41	29)	84	54	T	127	7F		170	AA		213	D5				
42	2A	*	85	55	U	128	80		171	AB		214	D6				